

# Quilt n' Pillow

**Pattern Level:** Beginner

**Finished size:** 44"x 59"- quilt, 15" pillow

**Seam allowances:** 1/2" seam allowance used throughout. Read all instructions before beginning. Press carefully step-by-step.



## Materials needed:

1 Watermelon pillow panel

2 1/4-yards red seed print

1 3/4-yards watermelon plaid

1 crib size batting, piece of batting 16"x 16", matching thread, clear monofilament thread (machine quilting)

## Cutting

### From red seed print cut:

1 square 16"

1 piece 45"x 60"

### From plaid cut:

1 piece 45"x60"

### From pillow panel cut:

1 square 16"

## Assembly:

- 1) Pin pillow panel and backing right sides facing on top of 16" batting square. See figure 1. Sew around top and side edges leaving the bottom open for turning. Clip corners and turn right side out. Quilt around motifs as desired. Pin pillow to red quilt back, centered along bottom edge with pillow panel facing down and raw edges even. Baste along bottom edge. See figure 2.
- 2) Pin quilt front to quilt back right sides facing on top of batting. Stitch around all edges leaving an opening for turning. Clip corners and turn right side out. Stitch opening closed. Pin pillow to red back side of quilt and stitch close to both side edges of pillow. The top of the pillow should remain open. Quilt along plaid lines as desired. See figure 3.
- 3) To fold quilt into pillow: Lay quilt on the floor with pillow side down. Fold sides of quilt one over the other using side edges of pillow as a guide. Fold quilt in half toward pillow and then in half again Turn pillow right side out and insert quilt into pillow.

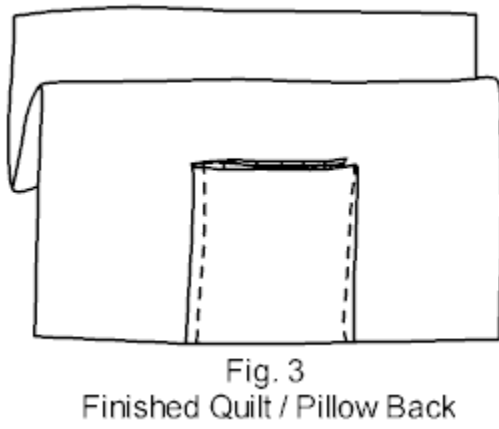
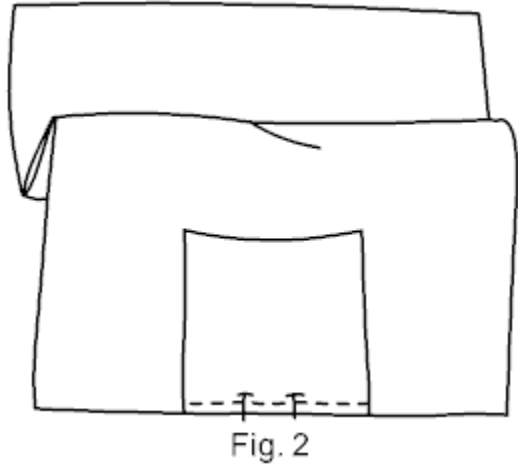
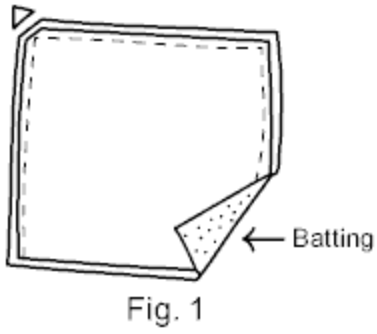

While all possible care has been taken to ensure the accuracy of this pattern, we are not responsible for printing errors or the way in which individual work varies.

©Cranston, a Division of ©Cranston Print Works Company  
[www.CranstonVillage.com](http://www.CranstonVillage.com)