

HERITAGE WALLHANGING AND PILLOWS

by Janet Page © 1998

100% Cotton

Pattern Level: Easy

Finished size wall hanging 54" x 54"

Pillows use 14" pillow form

1/4" seam allowances are used throughout and have been included

Materials needed:

- 1 yard 90" wide Heritage Baltimore Album print from Cranston Collections W6752-G
- 3 1/4 yards VO184-N V.I.P. Textures navy for backing, borders, and binding
- 1/3 yard VO191-B Textures light blue for border
- 1 1/4 yards VO190-B Textures medium blue for triangles, border which will have to be pieced
- 2/3 yard VO194-S Textures gold for outside sections
- *The one yard of Heritage fabric includes enough for 3 pillow fronts. Other yardages for pillow backing and borders/ruffles are given separately below.*



Pillow Yardage

- 1-3/4 yards VO190-BL Textures blue floral for ruffled and flange pillows
- 2/3 yard VO190-B Textures basket weave for button pillow

Other materials needed are twin sized batting or a piece that measures 58" x 58". Matching threads, small piece of fusible web for appliqué of bows. 3 - 14" pillow forms, 10 assorted white buttons 3/4" - 1".

Cutting Notes

Please refer to diagrams and photograph.

It is important to read over instructions before cutting. It is also important to

cut all of the vine sashing FIRST being very careful not to cut into panels.

Cutting measurements are on diagram 1. After sashing is cut, cut 4 -14" panels for wall hanging, (be sure to use the ones pictured in the photo). Cut 3 -14" panels for pillows: the round wreath, the basket and the bouquet. It is important to use these exact panels as you will need the leftover panels for the bow appliqué and floral squares.

Using a small piece of fusible web, fuse two bows. Cut out one bow from heart shaped wreath, the other bow from the other heart shaped wreath. Fuse in place on panels as pictured in photo. From remaining leftover panels, cut 3" squares of gold and wine flowers. From navy cut 4 - 3" squares for sashing. All other cutting measurements are on diagram 1. Extra inches have been added to lengthwise measurements of borders to allow for the way individual work may vary, trim where necessary after sewing.

Assembly

Piece together following instructions on diagrams 1 and diagram 2 for wall hanging, pillow instructions are below. When top is complete cut backing, 58" x 58", it will have to be pieced. Cut batting same size. Assemble the quilt "sandwich" by placing the backing, batting and top together in layers and baste or pin with safety pins. Machine quilt in all seam lines and outline quilt around wreaths and vines or as otherwise desired. When machine quilting is completed, trim excess batting and backing. Bind in the usual manner.

Assembly for Pillows

Also see diagram 3. **For ruffled pillow:** cut 14" square panel. Cut 4 strips 5" x 44" long of 1. blue floral. Sew short ends together to form one long strip. Sew last two short ends together. Fold strip lengthwise, wrong sides together, matching raw edges and press. Sew a gathering stitch 1/4" from raw edge around whole edge. Using seams in the strip as a guide, pin one seam at each corner of pillow top matching raw edges. Pull up gathers to fit sides and pin in place. Repeat for each side. To assemble back, read general instructions below. When back flap hems are complete, overlap the two hemmed sides of the rectangles to form a 14" square and pin. Place the top with the ruffle pinned face up on table. Place the back on top, right sides together. Pin these pieces together carefully, making sure that the ruffle does not get caught in the seam line, especially at the corners. Sew around all four sides in a 1/4" seam allowance. Turn right side out through the overlapped back. Insert pillow.

For flange pillow: Follow cutting and sewing instructions on diagram 3. When top is complete, assemble the back, following general instructions. Sew top and back right sides together, turn right side out. Top stitch around 14" panel square

with monofilament thread through all layers. Optional - top stitch around the 1" border. Insert pillow.

For button pillow: Again follow diagram 3 for cutting. Sew the 2 - 4 1/2" border "ends" to center panel. Finish ends with a serger or zig-zag stitch on your sewing machine. Turn both edges in to meet seam line on wrong side. Cut back 14 1/2" x 20 1/2" (you will not need a flap as the buttons will be your opening). Finish two short edges of back as for front. Turn in 2" to wrong side and press. Make 5 buttonholes on each side of front to size of the buttons you have chosen. Sew buttons in place on back hem. Sew front and back together at top and bottom in a 1/4" seam allowance (right sides together). Turn inside out and insert pillow.

General instructions for making the opening on the back of the pillows.

Cut 2 pieces of backing fabric 14" x 10". Fold under one 14" side on each piece to form a 1" hem and sew hem in place with a straight stitch. Overlap backs to same size as front and pin. Place backs and front right sides together and stitch around all edges in a 1/4" seam allowance.

Diagram 1

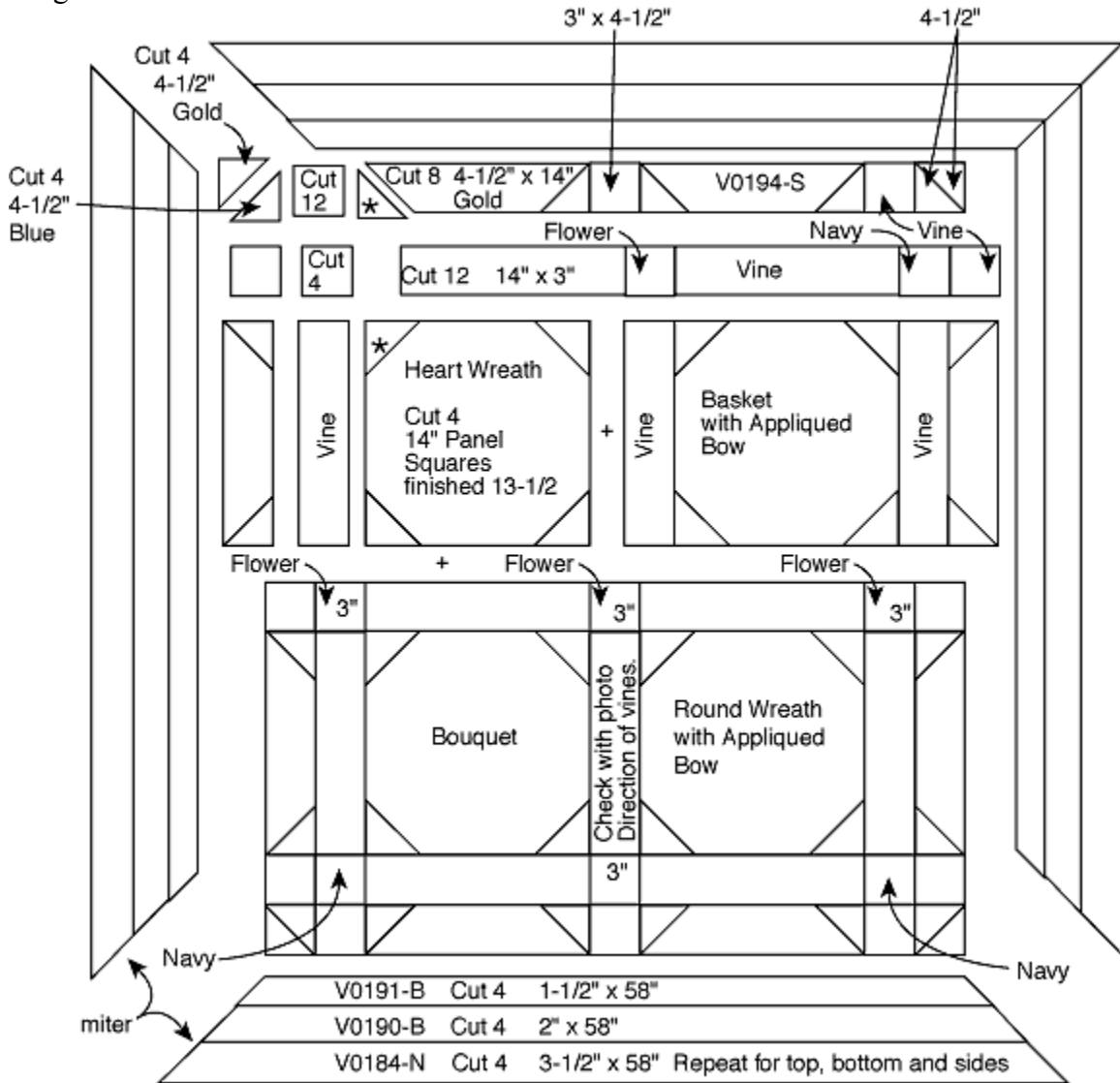
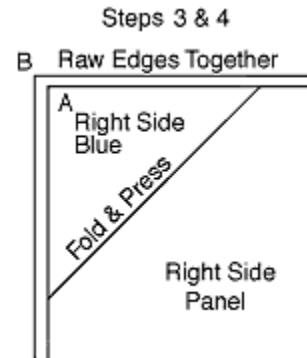
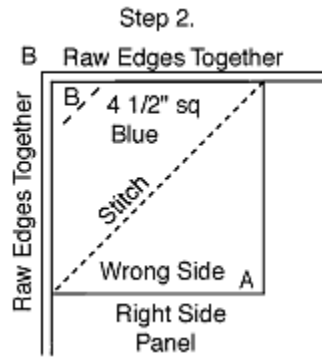
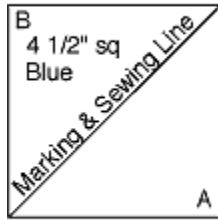
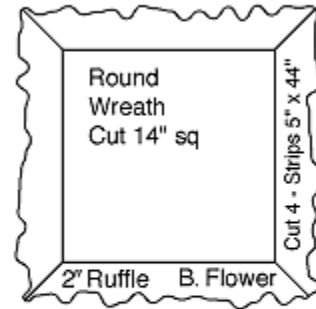
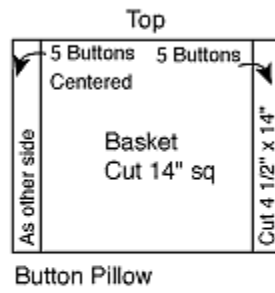
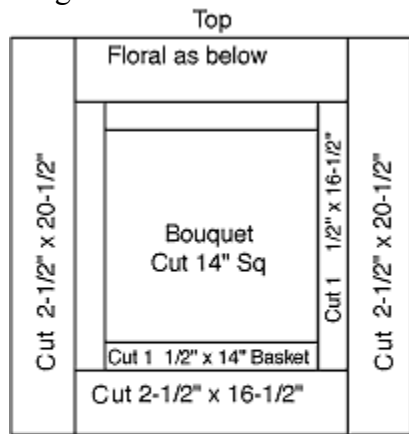

Diagram 2
Step 1.



1. Either mark square diagonally as shown or press in half as shown right sides together.
2. Pin corners B together, stitch across marked line.
3. Flip corner A up to B corners being sure raw edges are together.
4. Press. Trim corners B off to within 1/4" of seam line. Press again.
Repeat this technique for other blocks and gold rectangle borders

Diagram 3



Flange Pillow

While all possible care has been taken to ensure the accuracy of this pattern, we are not responsible for printing errors or the way in which individual work varies.